

PlazmaLift®

TavanLift Döner Model

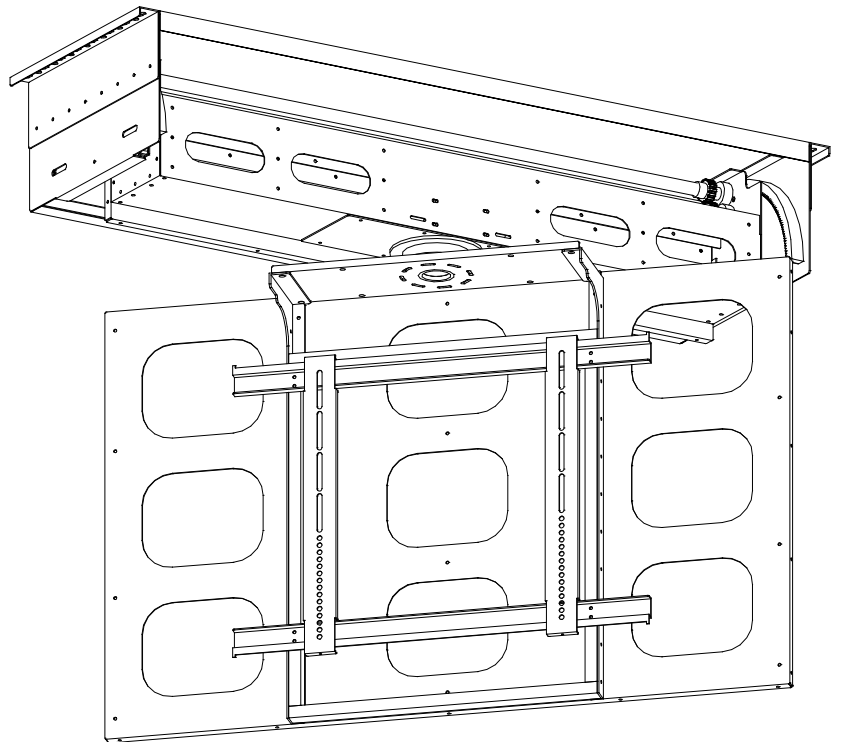

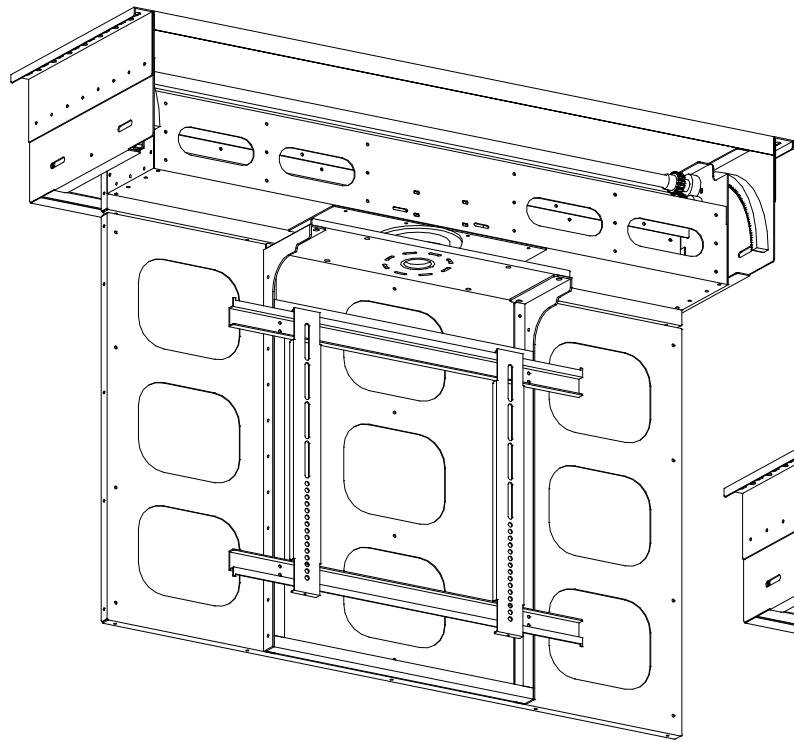
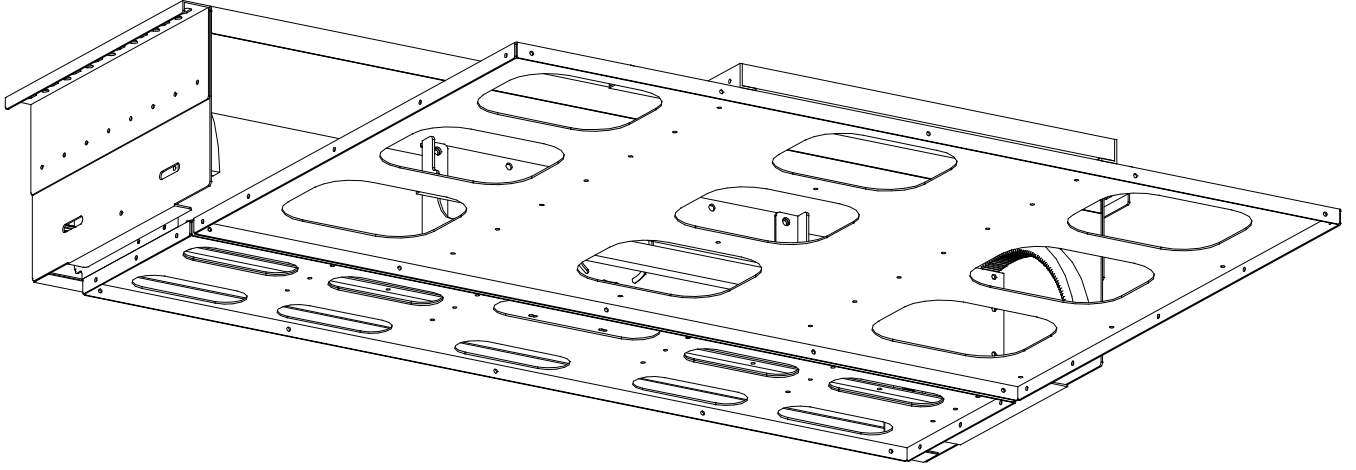
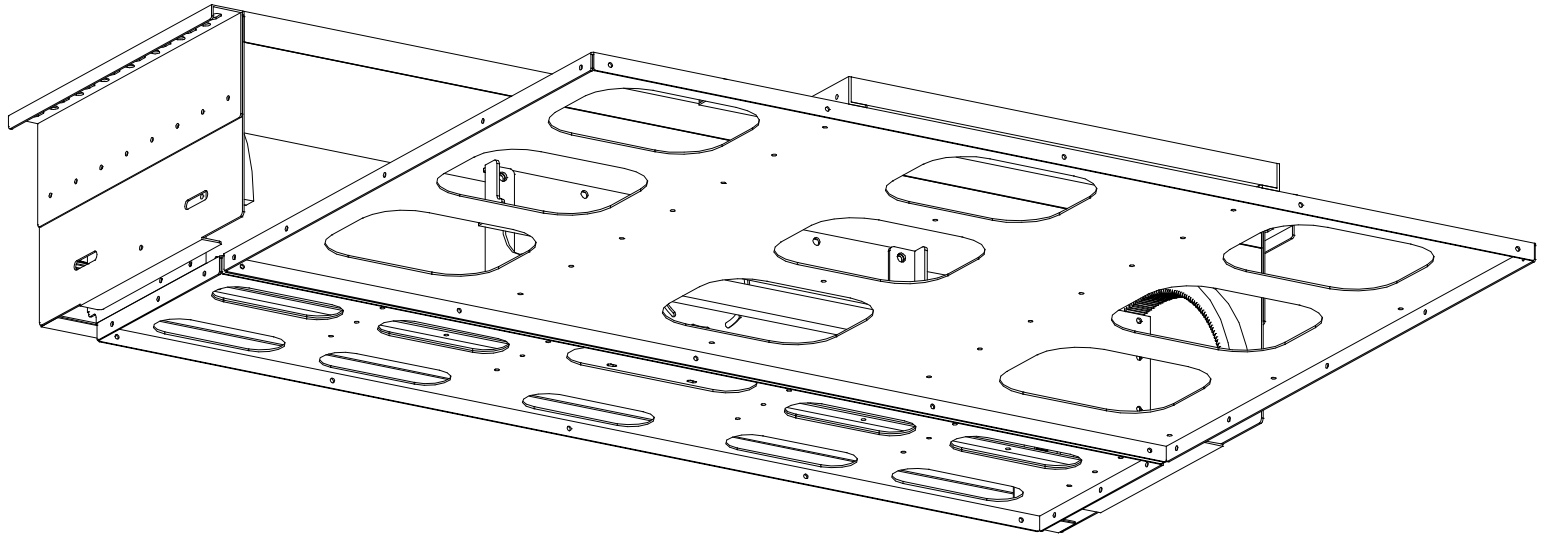
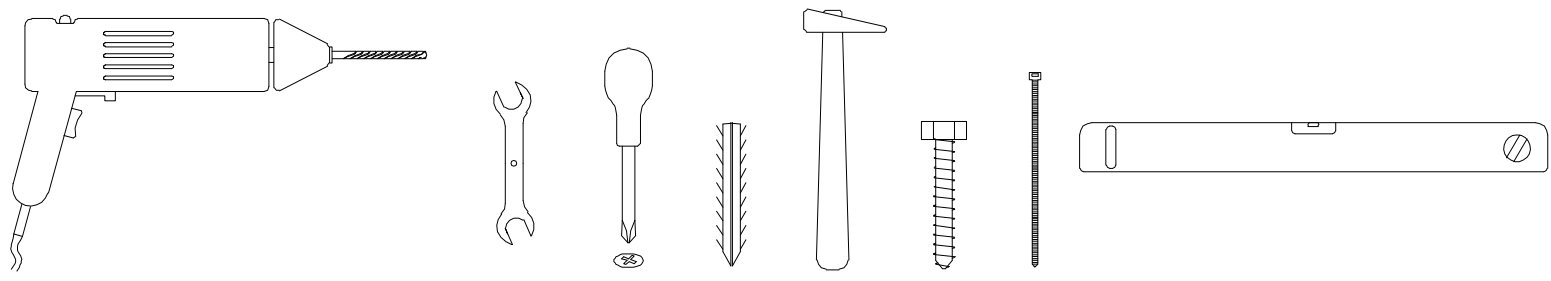

1x

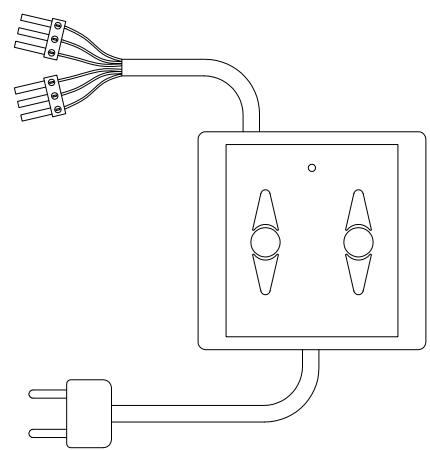

1x

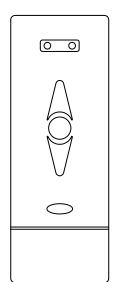

1x

1

Dö eme

Asma Tavan
Bo lu u

Asma Tavan

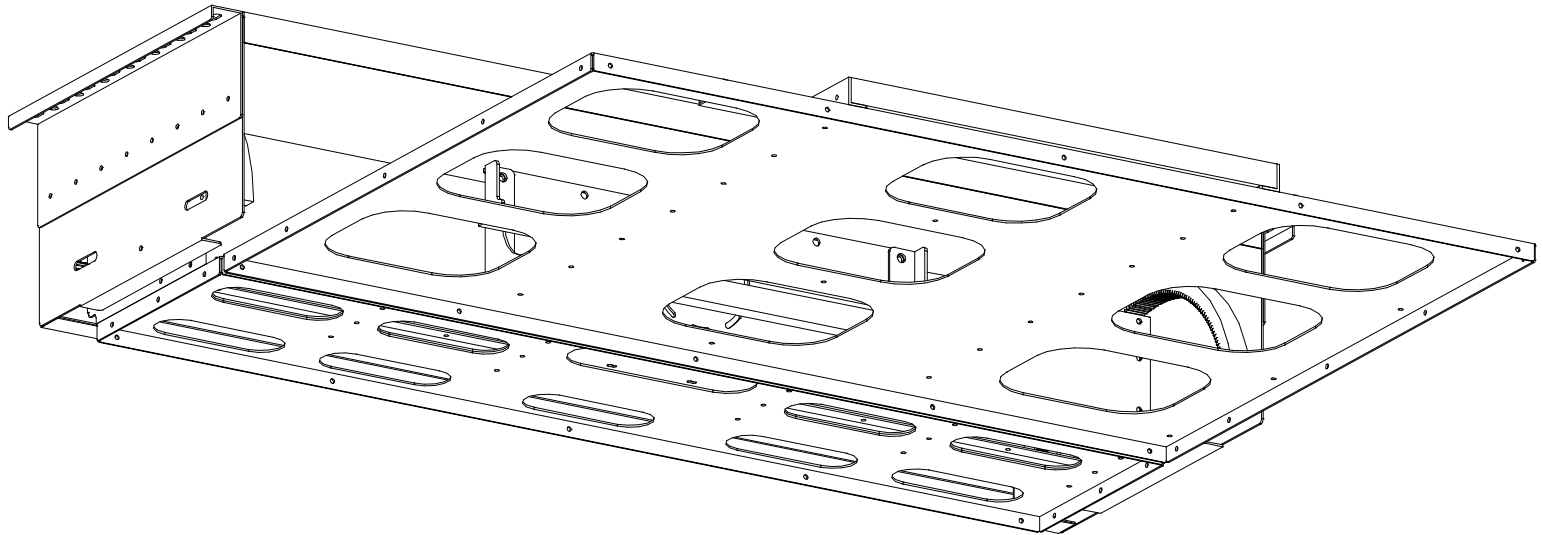

2

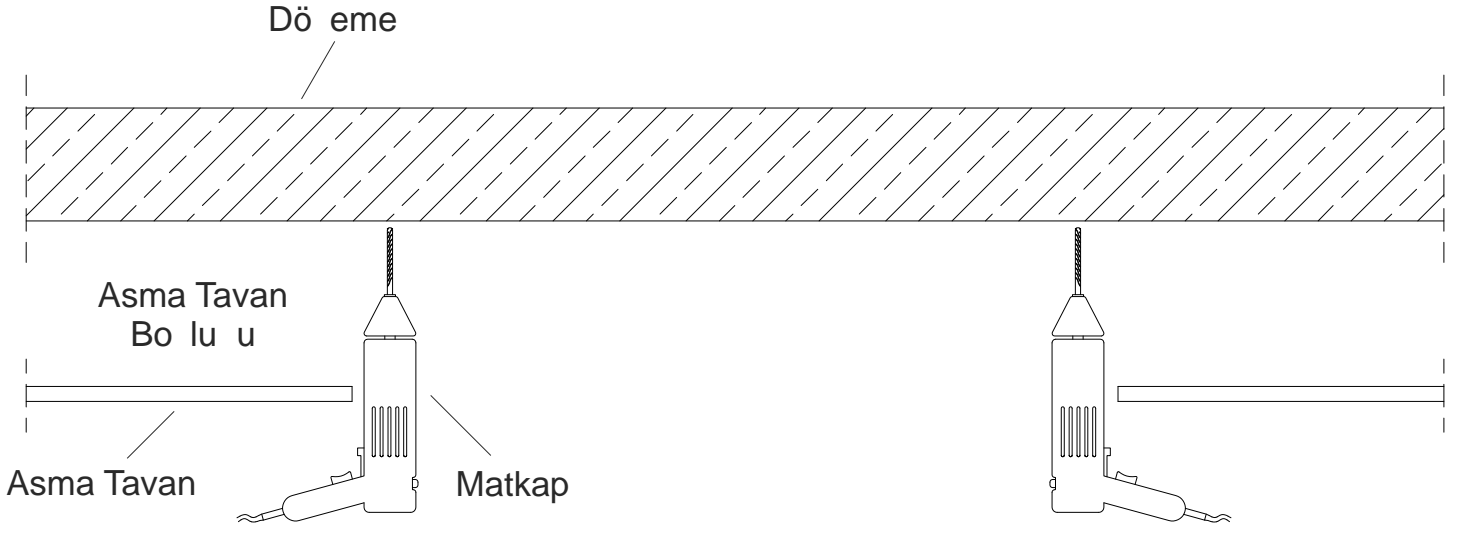

3

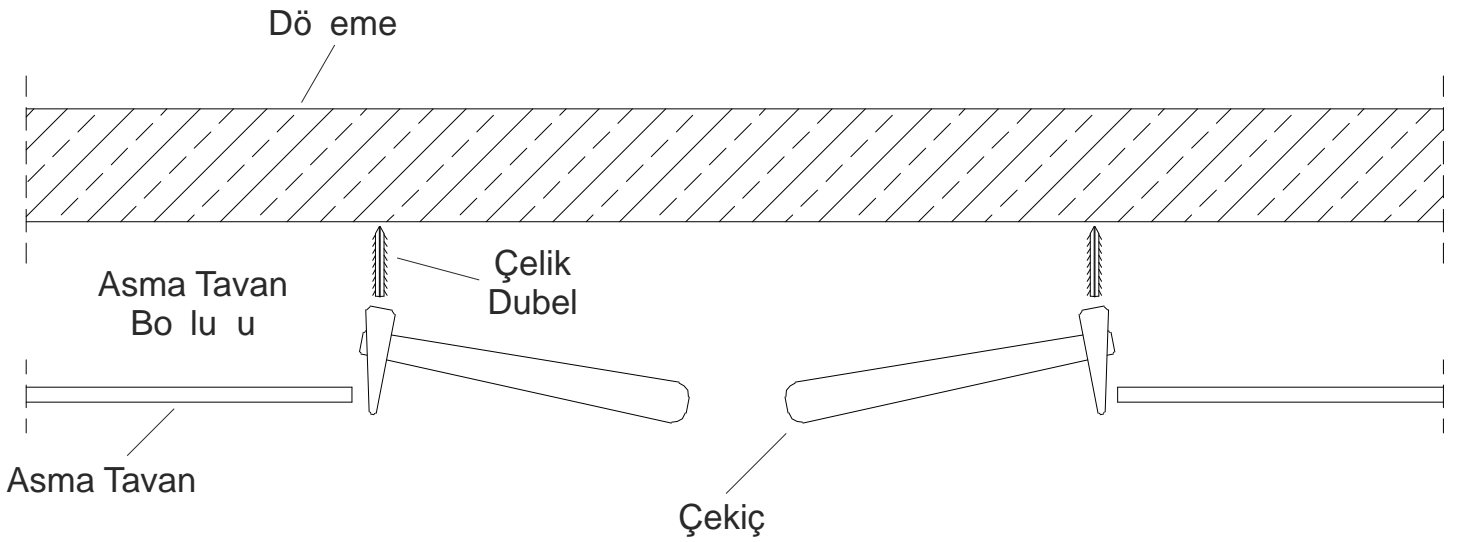

4

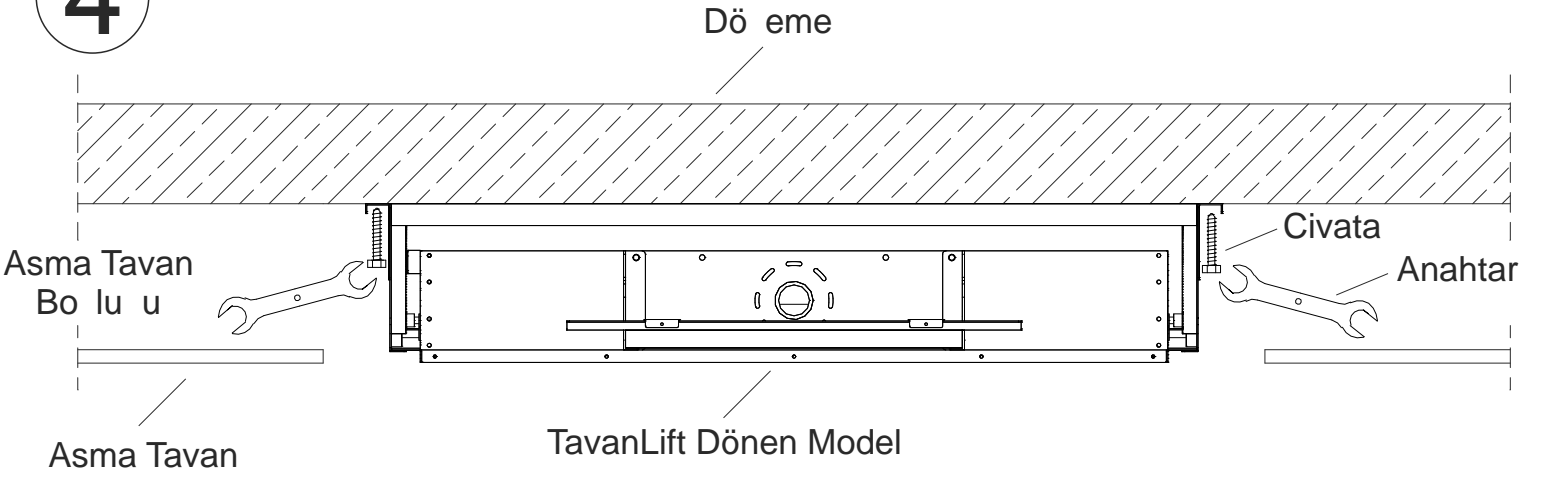

Alternatif Montaj Detayı

5

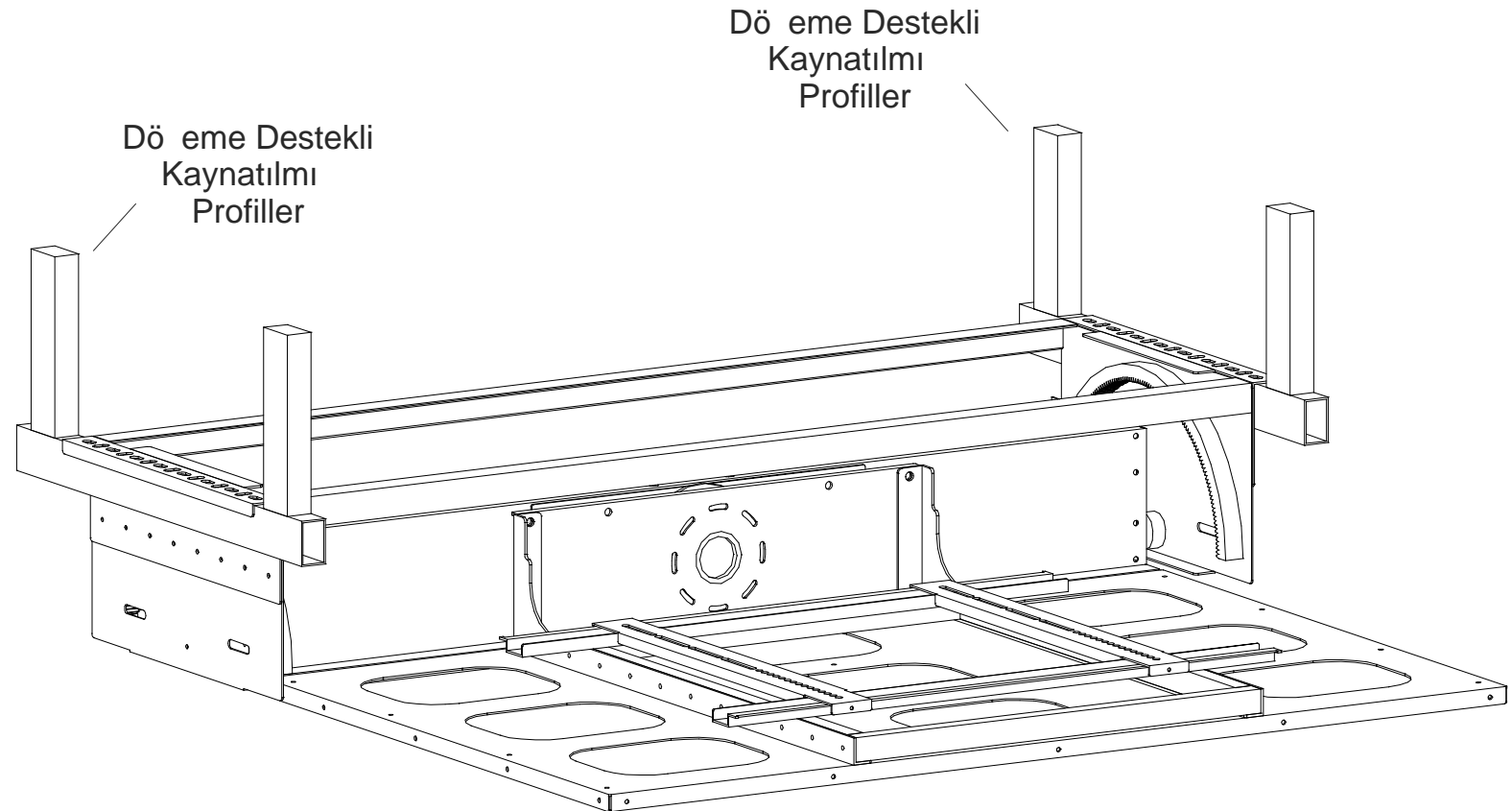

6

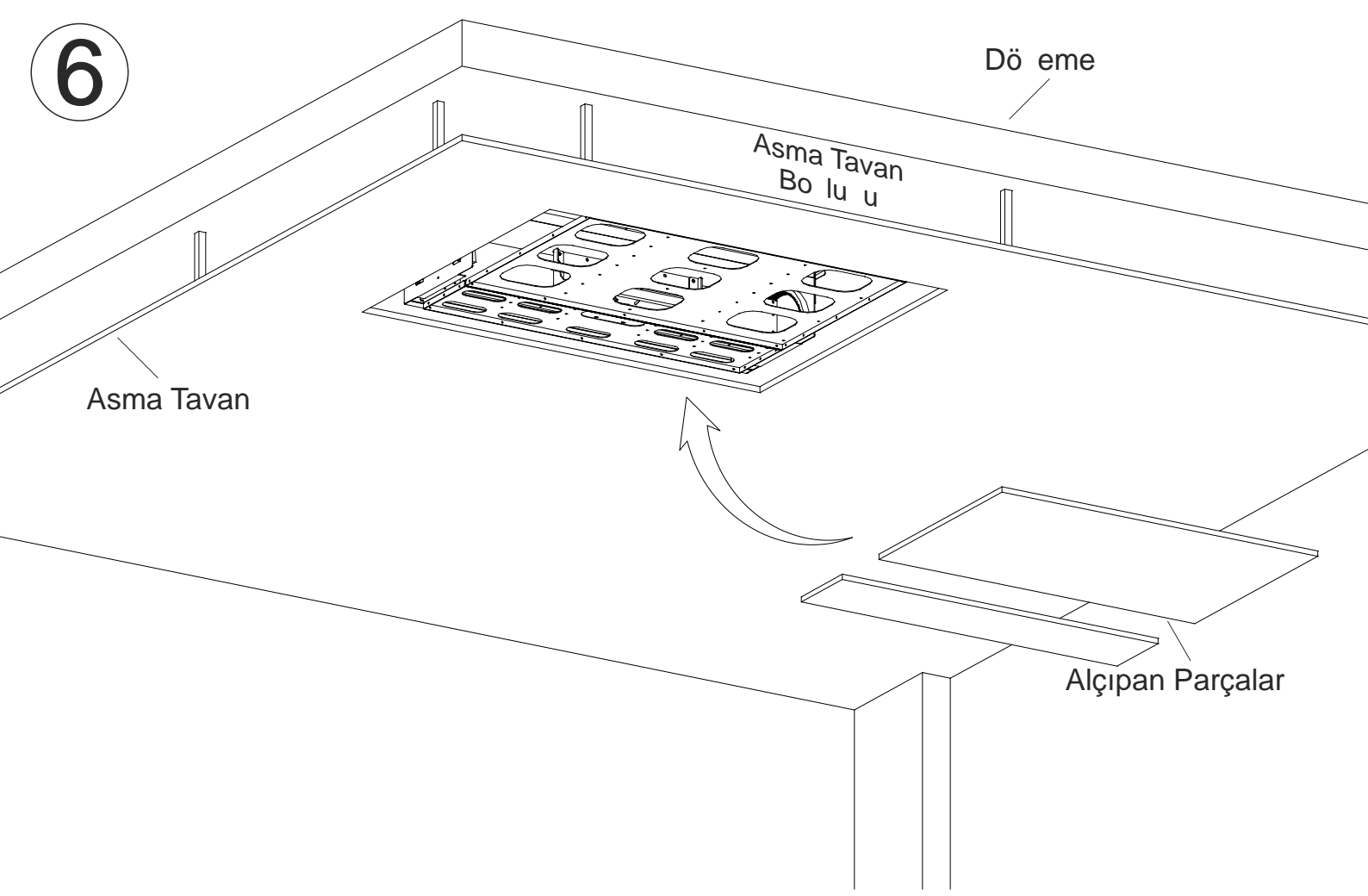

Dikkat: Arka kaplama yapılırken, dönme hareketli olan TV montaj bölümünün arka tarafı ayrı, dairesel hareketli olan motor kabininin arka tarafı ayrı bir şekilde kaplanmalıdır.

7

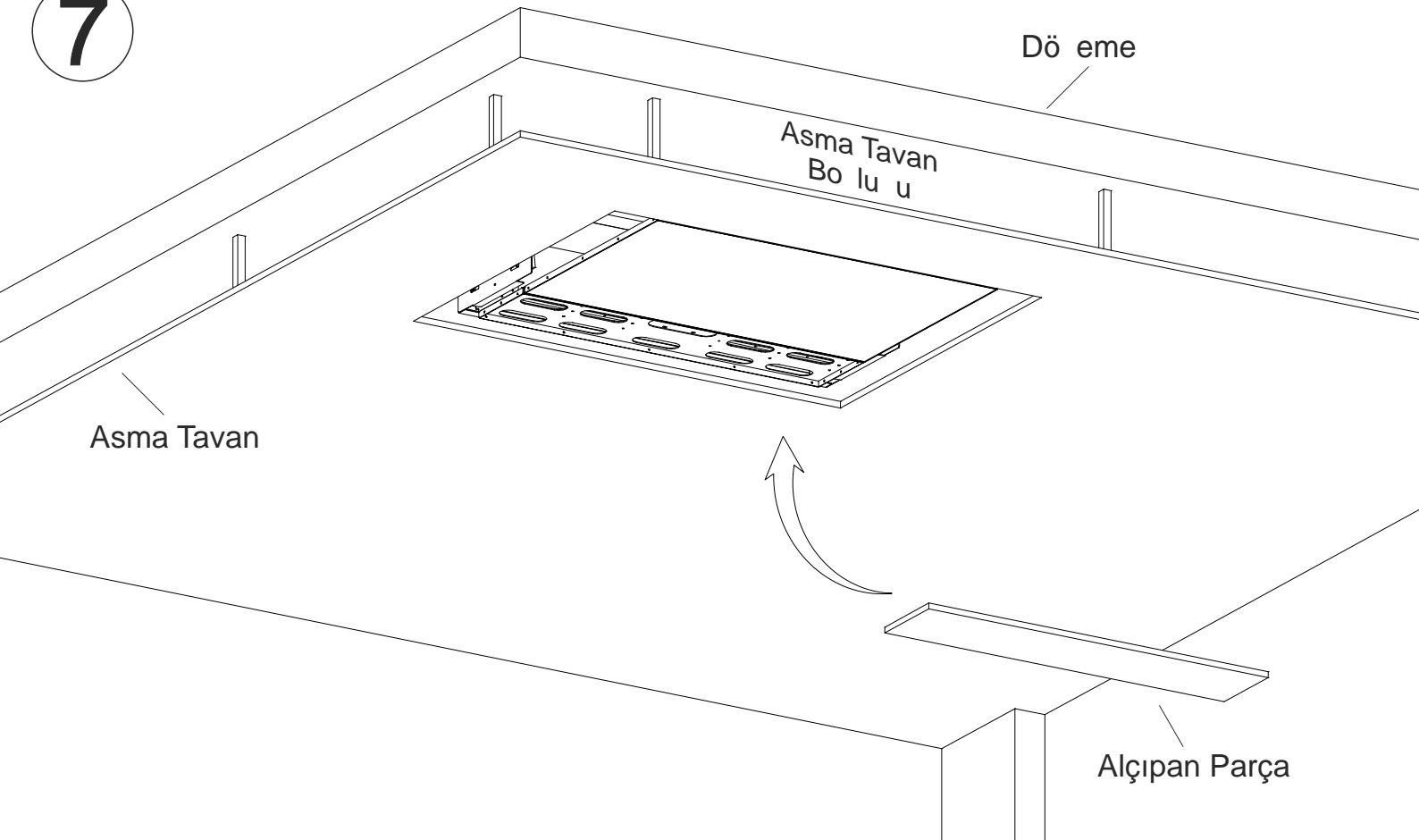

Dikkat: Arka kaplama yapılırken, dönme hareketli olan TV montaj bölümünün arka tarafı ayrı, dairesel hareketli olan motor kabininin arka tarafı ayrı bir şekilde kaplanmalıdır.

8

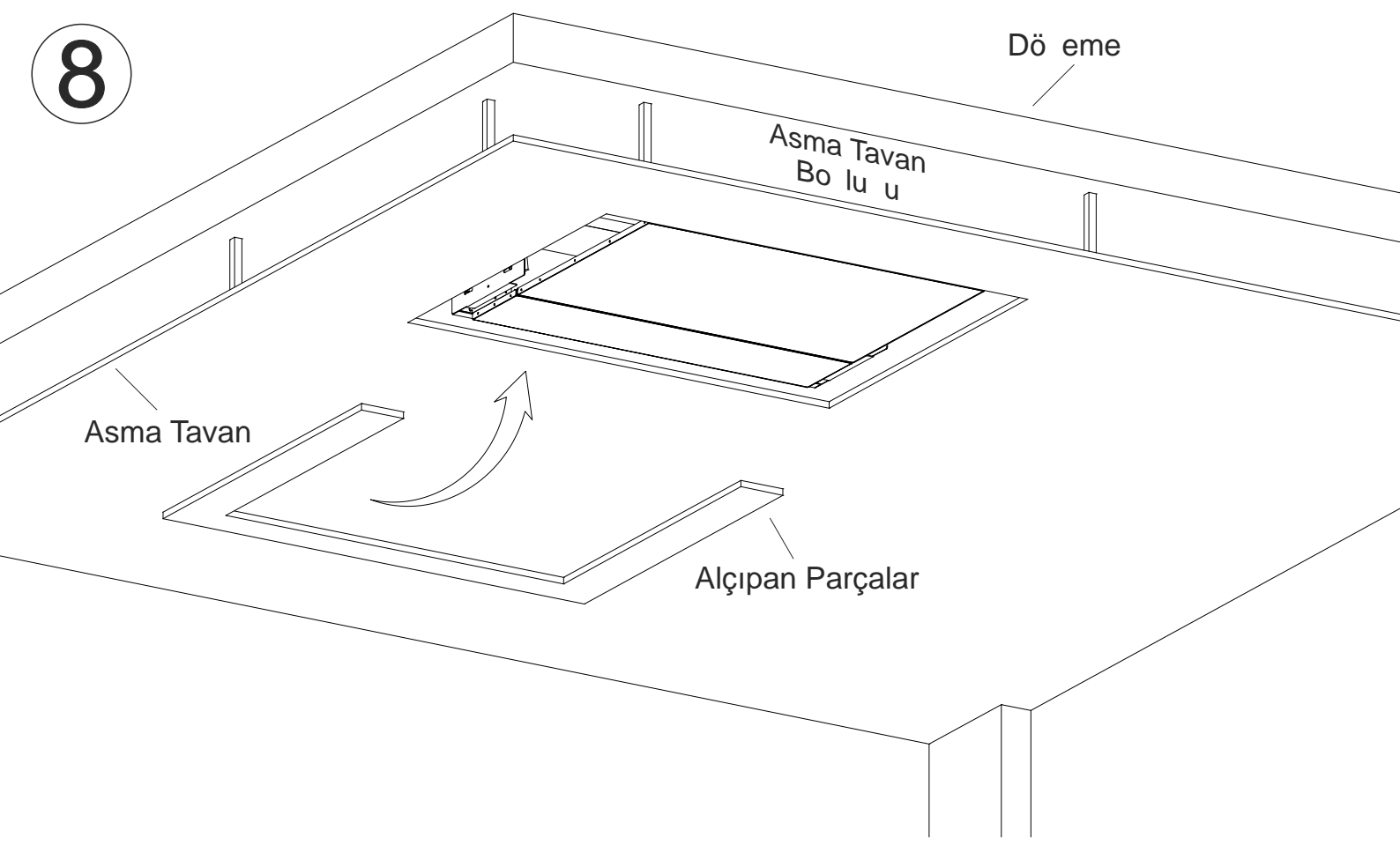

Not: Açık kalan kenarlar normal (sabit) bir eklede kaplanabilir.

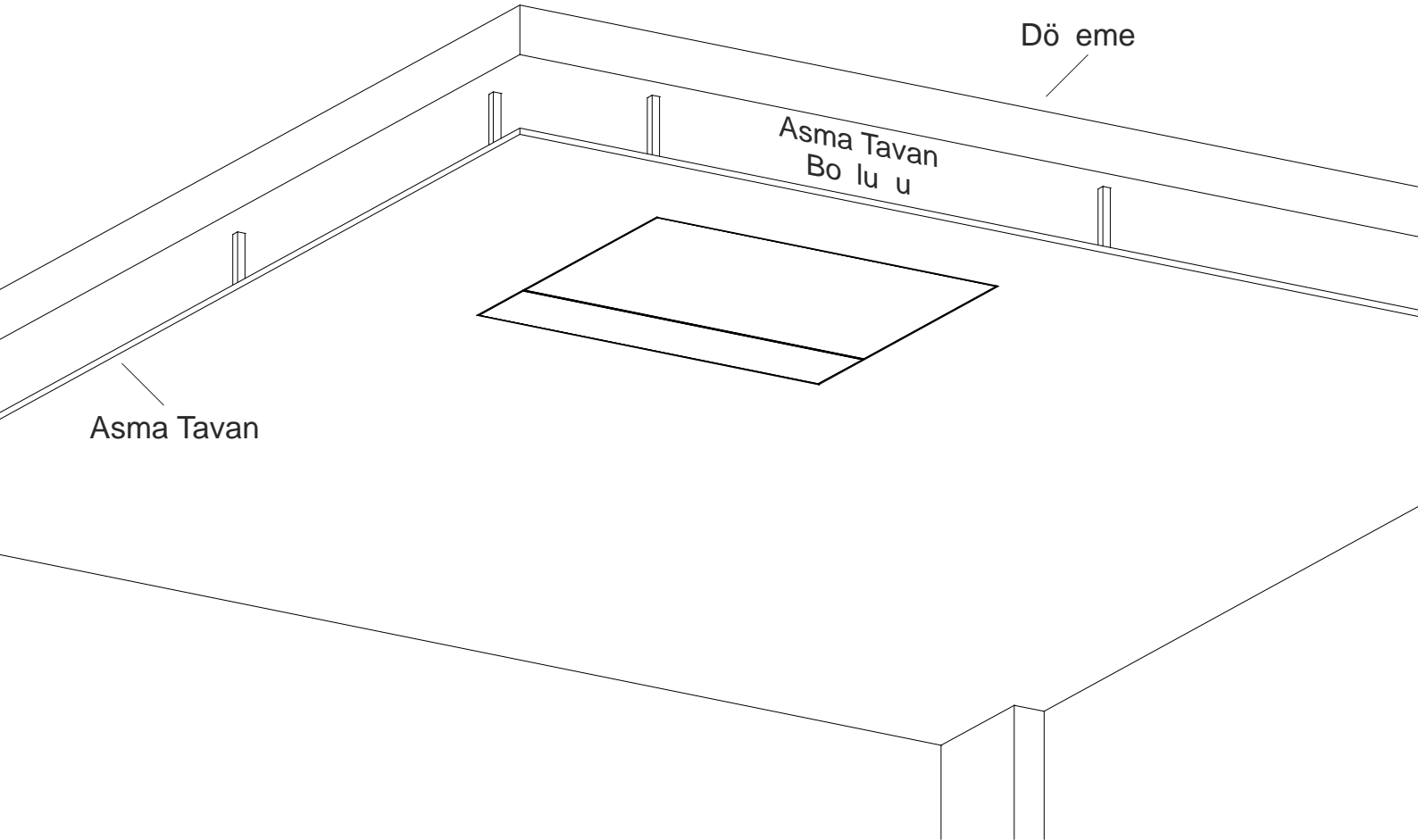

9

Dö eme

Asma Tavan
Bo lu u

Asma Tavan

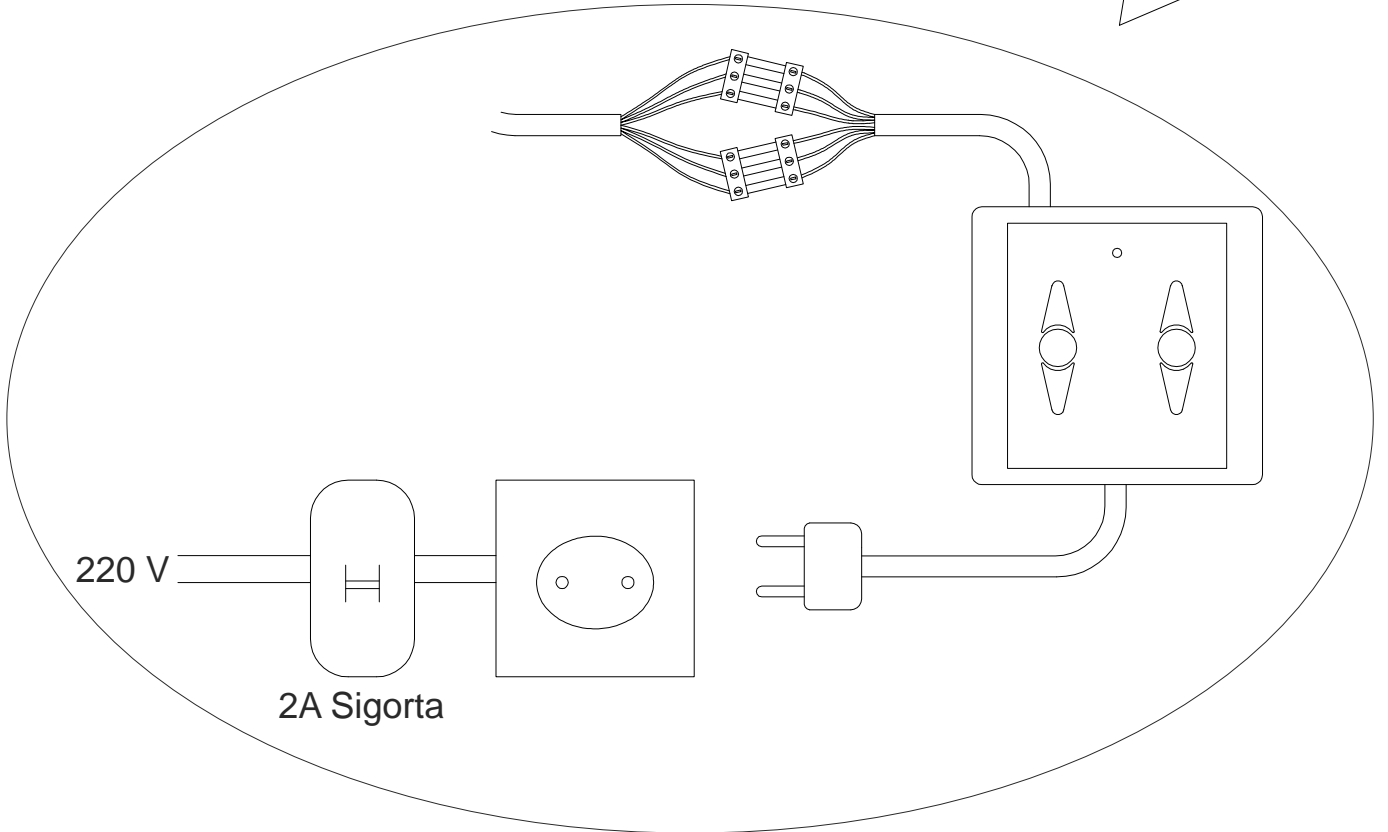

10 YUKARI

A A I

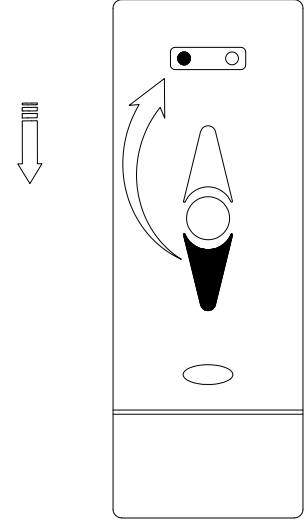
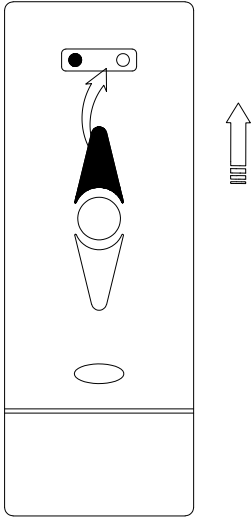

KANAL DE

T RME

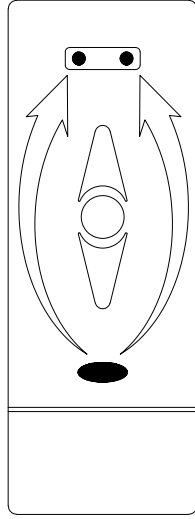

DÖNDÜRME

LER

GER

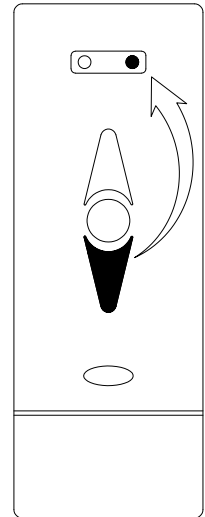
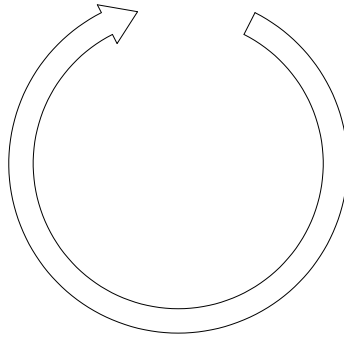
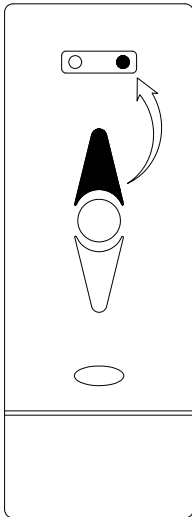

11

Dö eme

Asma Tavan
Bo lu u

Asma Tavan

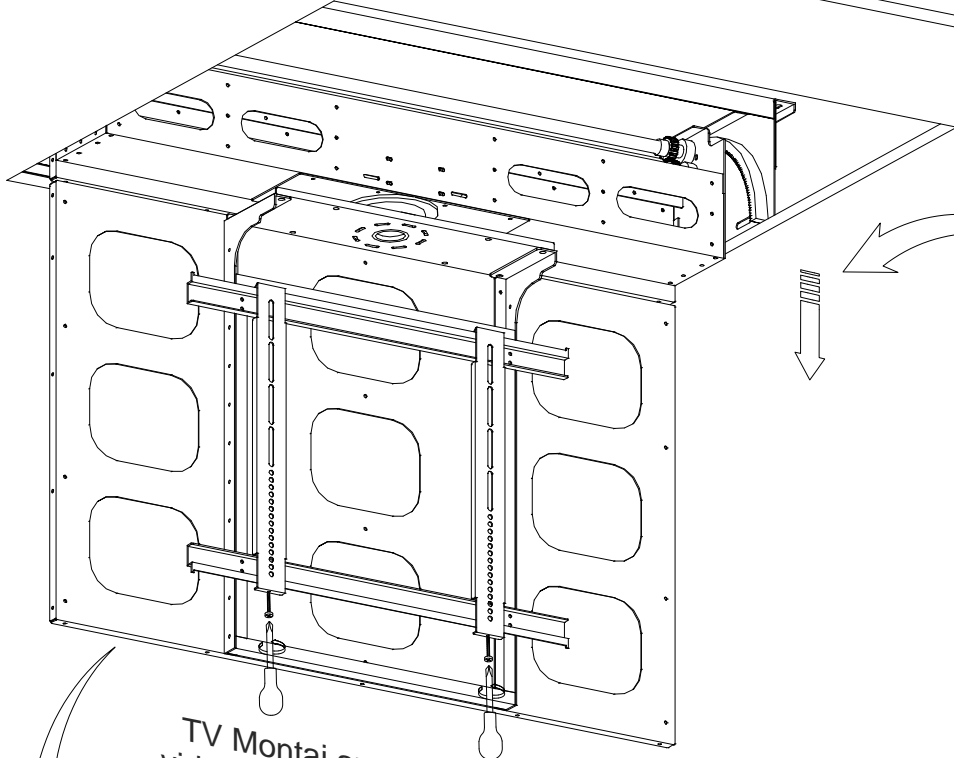

TV Montaj aparatlarını alttaki
vidalarından gev eterek Tv'nin
arkasına monte edilmelidir.

TV

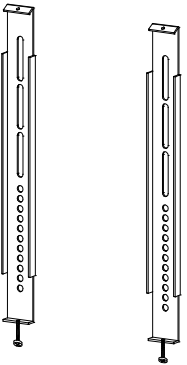
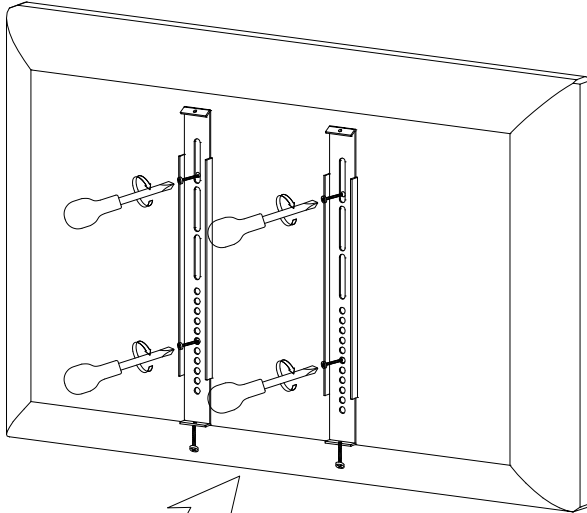

12

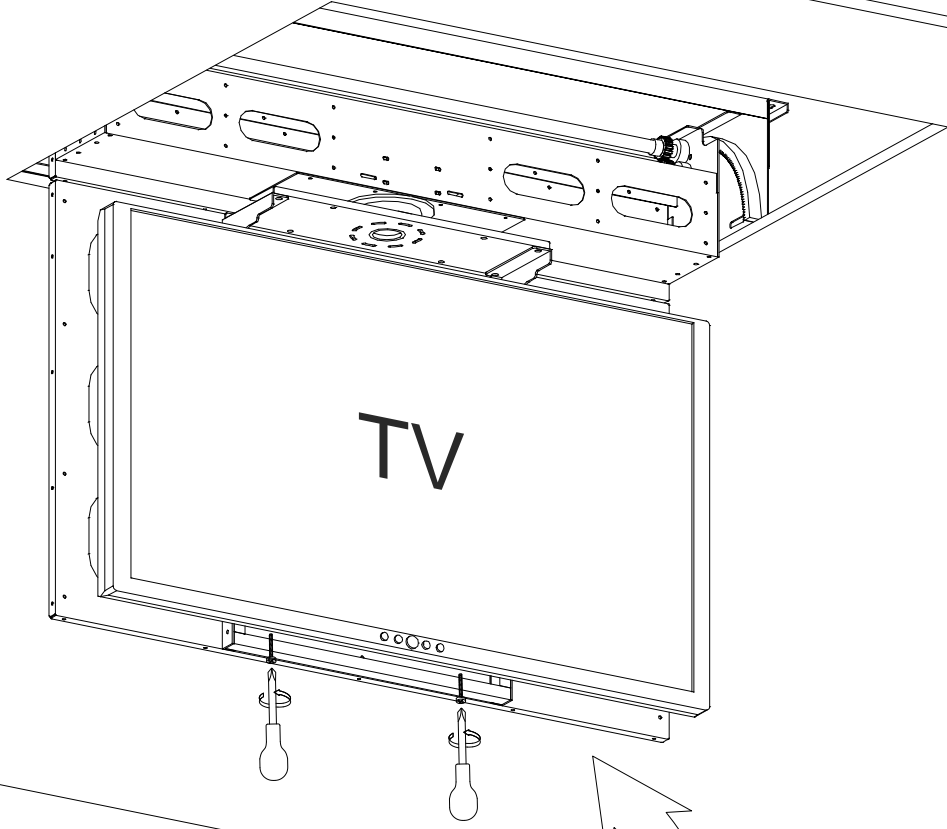

TV Lifte ekildeki gibi asıldıktan ve ortalandıktan sonra alttaki vidaların sıkılması gerekmektedir.

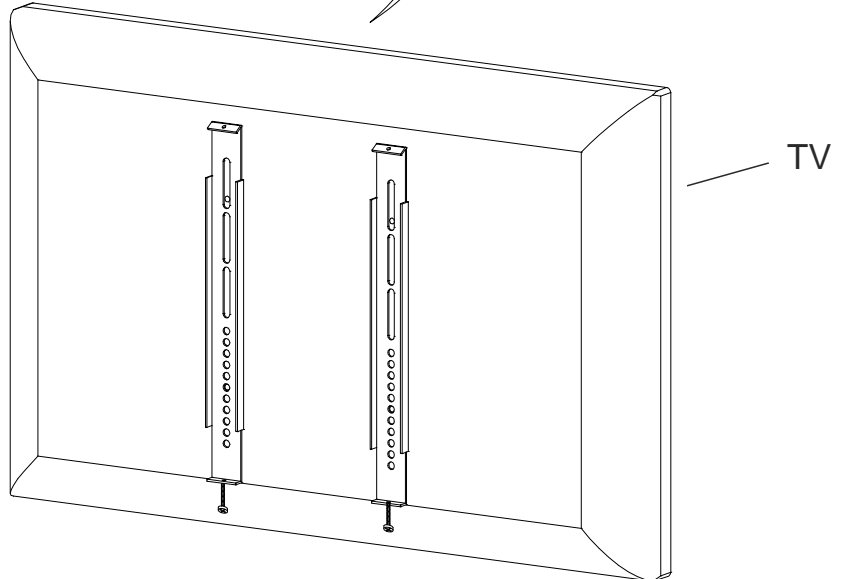

13

Dö eme

Asma Tavan
Bo lu u

Asma Tavan

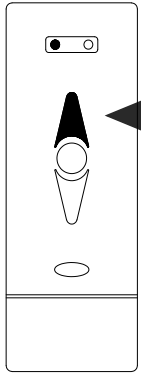

YUKARI

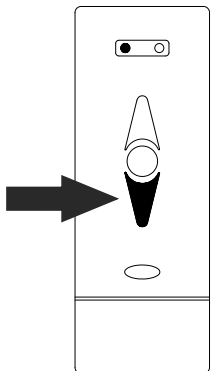

A A I

14

Dö eme

Asma Tavan
Bo lu u

Asma Tavan

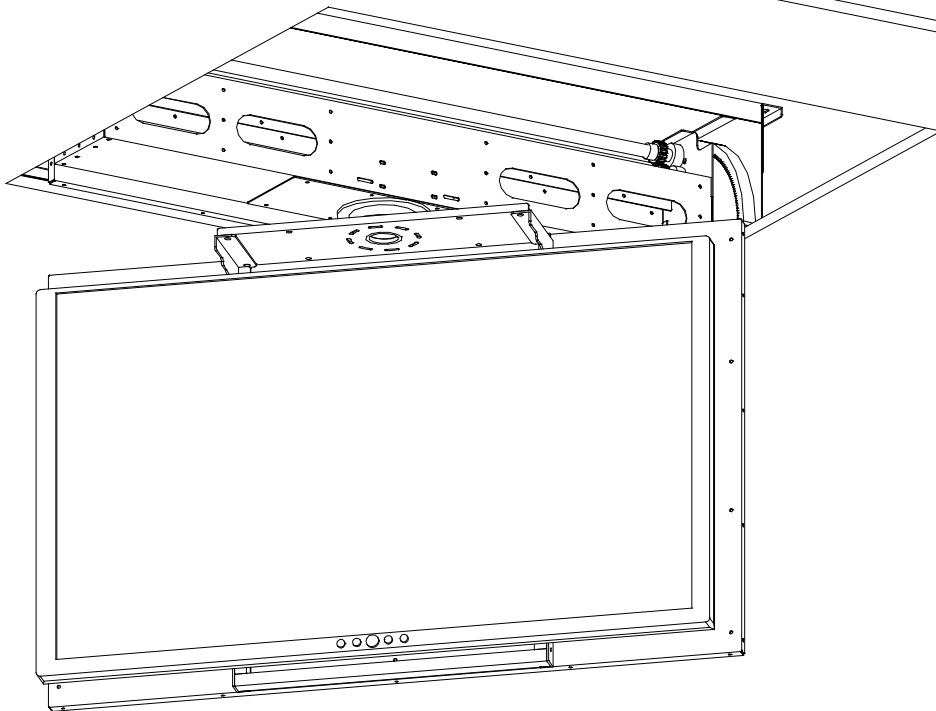

LER

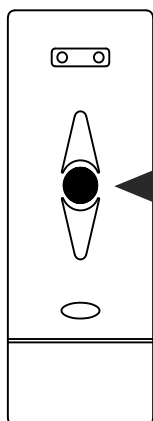
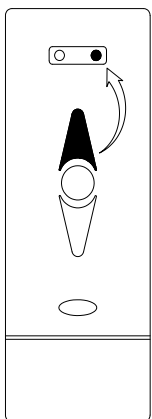

DURDURMA

GER

